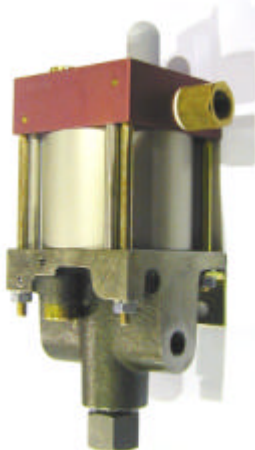

Technical Sheet Release: 7/2000	MO72	Oil service	
 <p style="text-align: center;">MO72 Single acting, single air drive head (Standard = Bottom inlet)</p>	Technical Data:		
	Air Drive Pressure:	1–10 bar/14,5–145 psi	
	Calculated Outlet Pressure at an air drive of 10 bar / 145 psi	880 bar/ 12,760 psi	
	Pressure ratio:	1 : 88	
	Displacement Volume/Double Stroke:	1.5 cm ³ / 0.09 cu.inch	
	Connections:		
	Inlet:	Standard: Bottom inlet 3/8 BSP	
	Outlet:	1/4 BSP	
	Air Drive:	3/8 BSP	
	Maximum Operating Temperature:	60°C	
	Net weight:	3.0 kg	
	<i>Pressure and flow performances, please see enclosed graph.</i>		
	Material of construction:	Top cap:	Aluminium
		Air cylinder:	Aluminium
	Seal Package:	Polyurethane, Buna N	
	Pump Body:	GGG50	
	Piston:	1.4112	
Approximate Dimensions:			
	Height:	195 mm	
	Depth:	104 mm	
	Width:	112 mm	
	Side inlet:	MO72S	
	External pilot port modification:	MO72-DIR	
	Special inlet and outlet ports, i.e. NPT	MO72-NPT	
	Special seal material to handle special fluids on request.		
Available Accessories:			
Air control units for M series with filter pressure regulator, control pressure gauge and shut-off valve:	MO72 with C1		
To protect the pump against excessive outlet pressures or to limit the outlet pressure, a safety valve can be fitted to the air control unit in the air drive line:	MO72 with C1/SVair (The required outlet pressure has to be indicated.)		

Please consult factory for more information.

All technical and dimensional information subject to change. All General Terms and Conditions of sale, including limitations of our liability, apply to all products and services sold.

MAXIMATOR®

Dimension Drawing MO72

Lufteinlaß = Air Drive Inlet
Flüssigkeitseinlaß = Liquid Inlet
Flüssigkeitsauslaß = Liquid Outlet
Standard pump comes with BSP ports and bottom inlet.

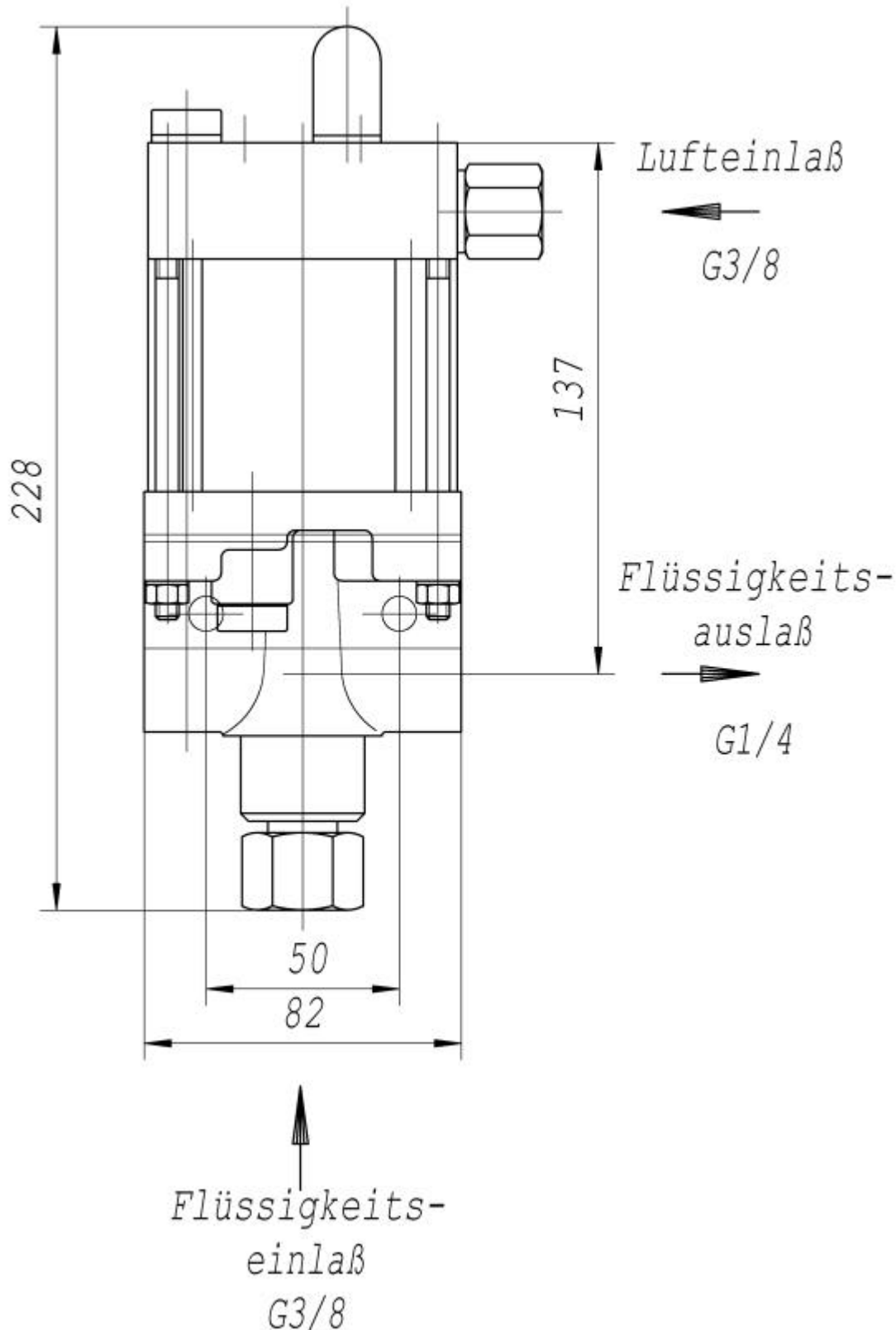

Leistungsdiagramm/Performance Graph

MO 72

Prüfflüssigkeit/Test Liquid: Wasser-Öl-Emulsion/Water Oil Emulsion ca. 1 - 10 cst

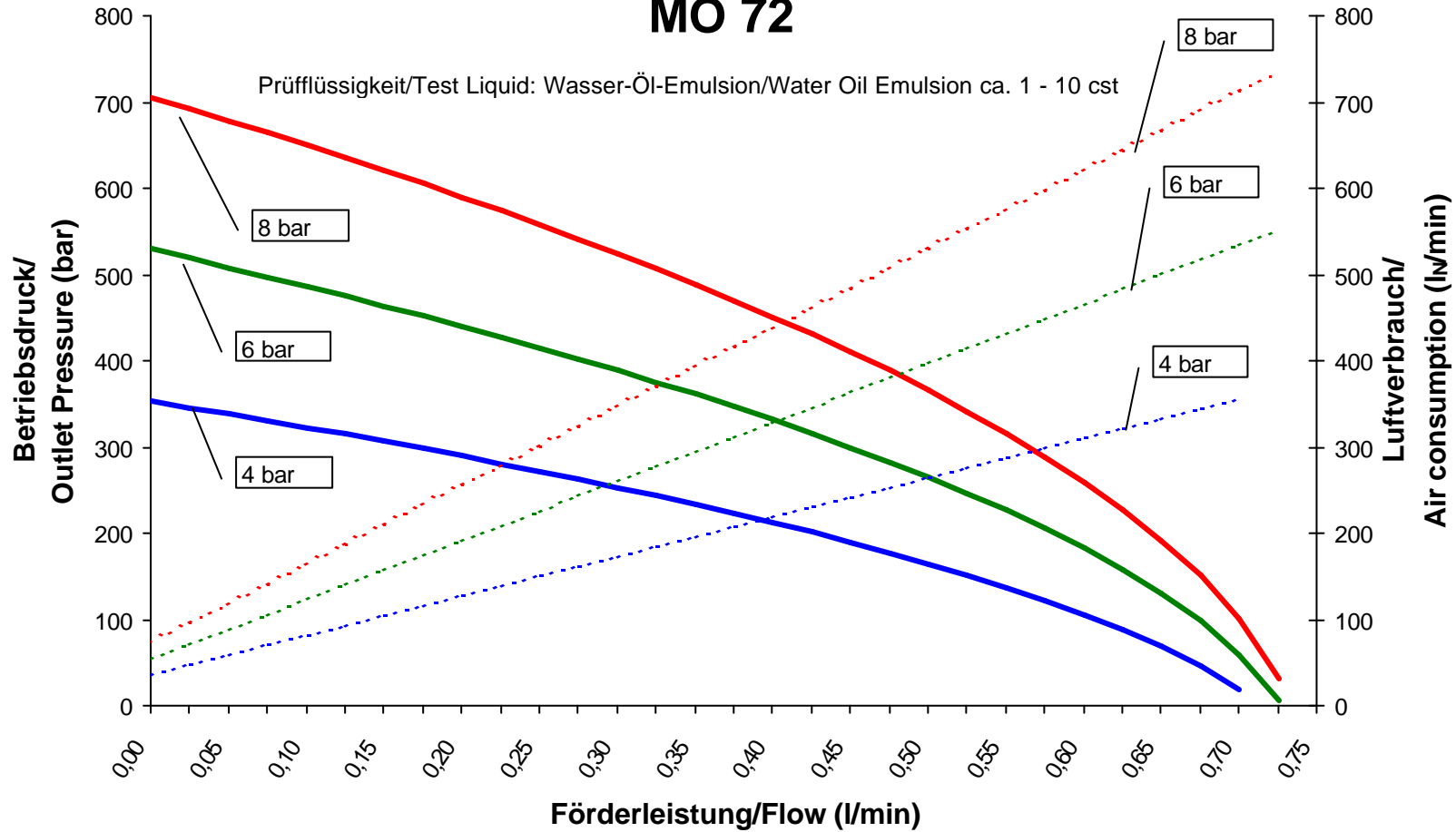

- Betriebsdruck bei/Outlet Pressure at 4 bar
- Betriebsdruck bei/Outlet Pressure at 8 bar
- Betriebsdruck bei/Outlet Pressure at 6 bar
- - - Luftverbrauch bei/Air consumption at 4 bar
- - - Luftverbrauch bei/Air consumption at 8 bar
- - - Luftverbrauch bei/Air consumption at 6 bar